

## Copper(II) Complexes with Some Tetrapeptides containing the 'Break-point' Prolyl Residue in the Third Position †

Cynara Livera and Leslie D. Pettit\*

*Department of Inorganic Chemistry, The University, Leeds LS2 9JT*

Michel Bataille and Jean Krembel

*Laboratoire de Chimie Biologique, L.A. 217, Université des Sciences et Techniques de Lille, 59655 Villeneuve D'Ascq Cedex, France*

Wojciech Bal and Henryk Kozłowski

*Institute of Chemistry, University of Wrocław, Joliot-Curie 14, 50383 Wrocław, Poland*

The tetrapeptides Phe-Gly-Pro-Phe, Phe-Gly-Pro-Tyr, and Tyr-Gly-Pro-Phe have been synthesised and their complexes with  $H^+$  and  $Cu^{2+}$  studied by potentiometry and spectroscopy (u.v., visible, c.d., and e.s.r.) at 25 °C and  $I = 0.10 \text{ mol dm}^{-3}$  ( $KNO_3$ ). The results show that with both tetrapeptides containing the Tyr residue,  $TyrO^- - Cu$  bonding is present at  $pH > 8$ . With Tyr-Gly-Pro-Phe this is achieved through the formation of dimeric complexes while with Phe-Gly-Pro-Tyr a monomeric complex with a large chelate ring is formed.

The term 'break-point' peptide was introduced recently to describe short-chain peptides which contain the prolyl (Pro) residue at an intermediate position in the chain.<sup>1-7</sup> Among biologically active metal ions, the break-point effect is most important with copper since  $Cu^{II}$  can deprotonate a peptide nitrogen, forming a  $N^- - Cu$  bond, at intermediate pH values. With normal peptides such as tetra-alanine (HL), the first complex to be formed by  $Cu^{II}$ , starting at low pH, involves co-ordination to the terminal amino N atom and the oxygen of the neighbouring carbonyl group (generally a  $[CuL]$  species with one N co-ordinated). As the pH is raised the  $Cu^{II}$  is able to deprotonate successive peptide nitrogens, forming  $N^- - Cu$  bonds, until eventually the  $[CuH_3L]$  complex (a 4N species) is formed around  $pH 9$ .<sup>8,9</sup>

Proline is the only naturally occurring amino acid with a secondary nitrogen atom, hence it is not protonated when incorporated in a peptide linkage. If Pro is the N-terminal residue the nitrogen can bind to  $Cu^{II}$  in the normal fashion but when within the peptide chain it cannot form a  $N^- - Cu$  bond and hence forces a break in the co-ordination sequence. In the simplest cases this leads to the formation of large chelate rings.<sup>2</sup> Both Pro and tyrosine (Tyr) are important amino acid residues in many neuropeptides and related molecules,<sup>5</sup> and our recent study of the complexes formed between  $Cu^{II}$  and a number of peptides containing the Pro and Tyr residues has shown that the Pro residue can enforce not only very specific peptide conformations, but also the formation of monomeric and dimeric complexes with very effective copper-phenolate oxygen bonds.<sup>3,7</sup> In particular, work on the  $Cu + Tyr-Gly-Pro-Tyr$  system<sup>7</sup> has revealed that, as a consequence of a break-point Pro residue in the third position of the peptide chain,  $Cu-O^-(Tyr)$  bonds are formed above  $pH 7.5$ . Since the tetrapeptide Tyr-Gly-Pro-Tyr contains two Tyr residues the precise role of each residue in complex formation was not clear. We therefore now report the synthesis of three related tetrapeptides: Tyr-Gly-Pro-Phe, Phe-Gly-Pro-Tyr, and Phe-Gly-Pro-Phe (where Phe = phenylalanine and Gly = glycine), and the results of a study of their copper(II) complexes, in order to clarify the picture.

### Experimental

**Peptide Syntheses.**—The tetrapeptides were synthesised by standard liquid-phase methods using, as starting materials,

† Non-S.I. unit employed:  $G = 10^{-4} \text{ T}$ .

Bu'OCO-Gly, -Pro, -Phe, -Tyr( $OCH_2Ph$ ), HCl·Phe- $CH_2Ph$ , and HCl·Tyr( $OCH_2Ph$ ) $CH_2Ph$ . The syntheses are outlined below.

Before the coupling step, C-protected derivatives (in chloroform solution) were neutralised with *N*-methylmorpholine. The coupling reagents were dicyclohexylcarbodi-imide (Merck) and 1-hydroxybenzotriazole (Aldrich). Benzyl groups were removed by hydrogenolysis using 10% Pd on charcoal as catalyst and Bu'OCO was cleaved using HCl ( $4 \text{ mol dm}^{-3}$ ) in dioxane. The peptides were purified by gel filtration (Sephedex G-15; eluant, water) followed by lyophilisation. Percentages of amino acids were checked by amino acid analysis.

**Potentiometric Studies.**—Stability constants for  $H^+$  and  $Cu^{2+}$  complexes were calculated from titration curves carried out at 25 °C using total volumes of 1.0–1.5  $\text{cm}^3$ . Alkali was added from a 0.1- $\text{cm}^3$  micrometre syringe which had been calibrated by both weight titration and the titration of standardised materials. Changes in pH were followed using a glass electrode calibrated in hydrogen-ion concentrations with  $HClO_4$ .<sup>10</sup> All solutions were of ionic strength  $0.10 \text{ mol dm}^{-3}$  ( $KNO_3$ ) and peptide concentrations of  $0.003 \text{ mol dm}^{-3}$ . Calculations were made with the aid of the SUPERQUAD computer program.<sup>11</sup> This allows for the refinement of total ligand concentrations and was able to confirm the purity of the peptides studied and in particular the absence of acetate, a frequent impurity in peptide samples, or other co-ordinating ions. In all cases duplicate or triplicate titrations were carried out at Cu:L ratios of 1:1 and 1:2. The standard deviations quoted were computed by SUPERQUAD and refer to random errors only. They give, however, a good indication of the importance of the particular species in the equilibrium.

**Spectroscopic Studies.**—Solutions were of similar concentrations as those used in the potentiometric studies, using  $Cu(ClO_4)_2 \cdot H_2O$  as the source of copper(II) ions. Absorption spectra were recorded on a Beckman UV 5240 spectrometer and circular dichroism (c.d.) spectra were measured on an automatic recording spectropolarimeter, JASCO-J-20, in the 800–200 nm region. All c.d. spectra are expressed in terms of  $\Delta\epsilon$  (i.e.  $\epsilon_1 - \epsilon_2$ ). E.s.r. spectra were obtained on a JEOL JES-Me-3X spectrometer at 130 K and at 9.13 GHz.

### Results and Discussion

**Hydrogen-ion Complexes.**—The neutral forms of Tyr-Gly-Pro-Phe and Phe-Gly-Pro-Tyr can both be regarded as  $H_2L$ .

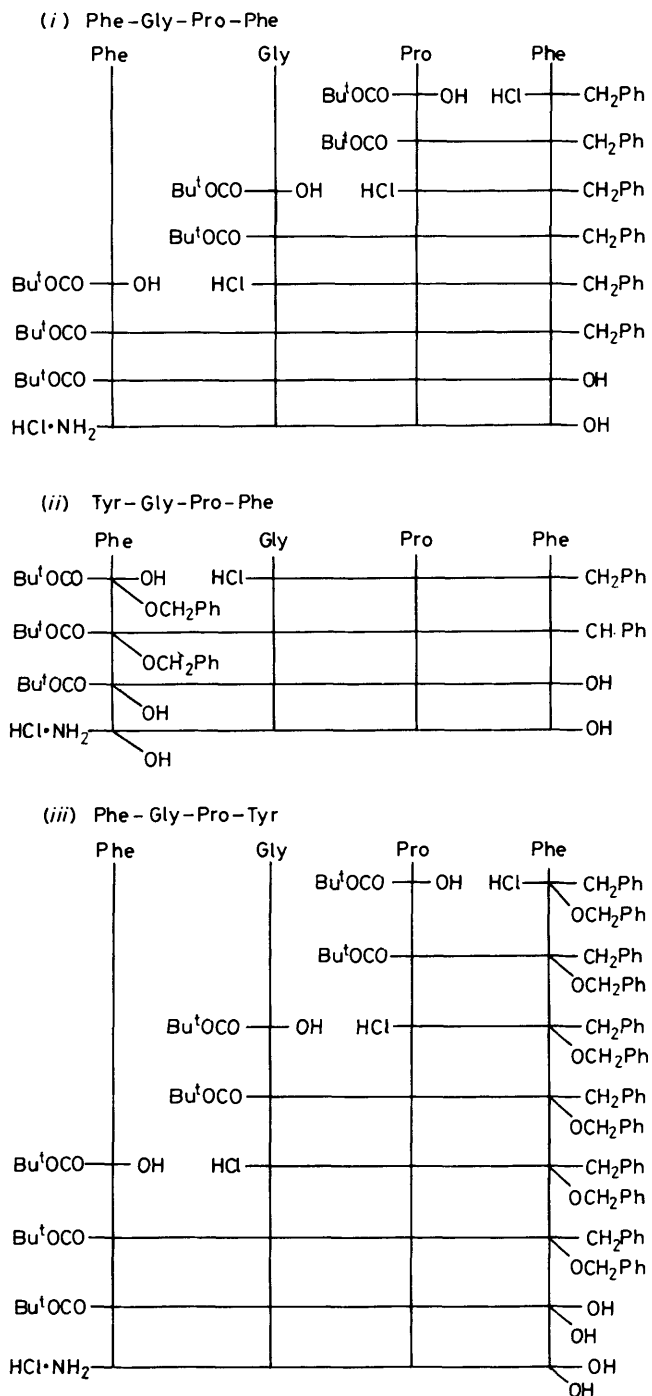

Both have three possible protonation centres: the terminal amino nitrogen, the C-terminal carboxylate, and the phenolic oxygen of the Tyr residue. The tetrapeptide Phe-Gly-Pro-Phe (HL) has only two possible protonation centres since it has no Tyr residue. The calculated protonation constants are given in Table 1. For the tyrosyl oxygens these constants are as expected, that for the N-terminal Tyr residue being somewhat lower than for the C-terminal residue due to the closer proximity of the charged NH<sub>3</sub><sup>+</sup> group. The protonation constants of the terminal amino groups are all almost identical, and the same as that found for Tyr-Gly-Pro-Tyr.<sup>7</sup> The carboxyl protonation constants for the two tetrapeptides with C-terminal Phe residues are also virtually identical, as expected.

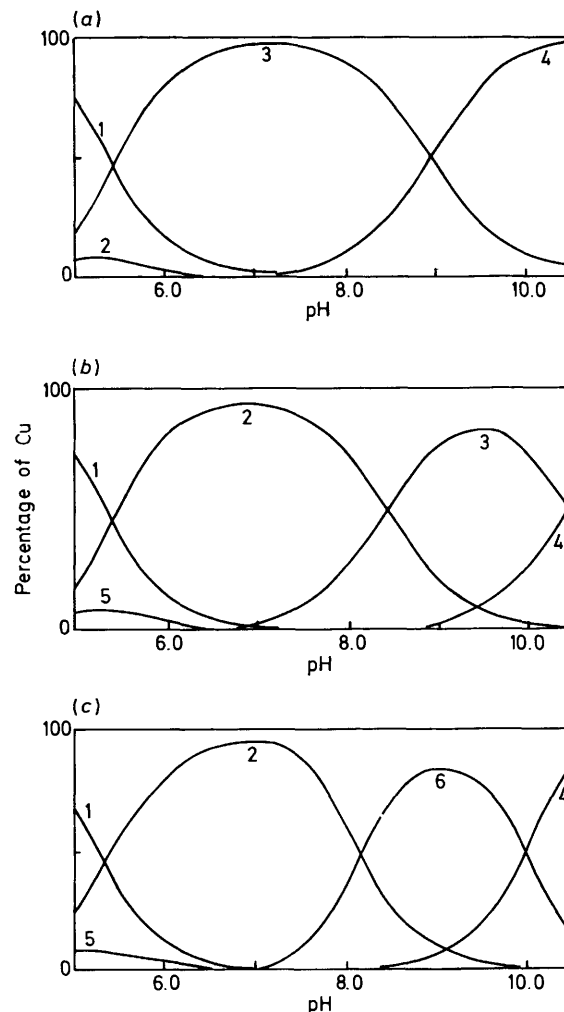

Figure 1. Species-distribution curves for 1:1 complexes of Cu<sup>2+</sup> with (a) Phe-Gly-Pro-Phe, (b) Phe-Gly-Pro-Tyr, and (c) Tyr-Gly-Pro-Phe (0.001 mol dm<sup>-3</sup>). Species. 1 = Cu<sup>2+</sup>, 2 = [CuL], 3 = [CuH<sub>1</sub>L], 4 = [CuH<sub>2</sub>L], 5 = [CuHL], and 6 = [CuH<sub>1</sub>L]<sub>2</sub>.

**Copper(II) Complexes.**—Stability constants of complexes with Cu<sup>II</sup> are given in Table 1 and species-distribution curves, calculated for 0.001 mol dm<sup>-3</sup> solutions, are shown in Figure 1. The spectroscopic details of the complexes are given in Table 2.

The tetrapeptide Phe-Gly-Pro-Phe contains no co-ordinating side chains so would therefore be expected to form similar complexes to those with other simple peptides with Pro in the third position (e.g. Gly-Gly-Pro-Gly).<sup>2</sup> This is found to be the case, the sequence of complex formation being [CuL] → [CuH<sub>1</sub>L] → [CuH<sub>2</sub>L]. The [CuL] complex, a minor species, would be bonded through the terminal amino N and the vicinal carbonyl oxygen (1N). This is rapidly replaced, as the pH is raised, by the [CuH<sub>1</sub>L] species which is a 2N complex bonded through the terminal amino N and the peptide N of the Gly residue. This is the major species up to pH 8, co-ordinating all the Cu<sup>II</sup> at around pH 7 [see Figure 1(a)]. This species is clearly characterised by the spectroscopic studies confirming 2N co-ordination with ligand-to-copper charge-transfer transitions typical of both NH<sub>2</sub>-Cu and N<sup>-</sup>-Cu interaction (see Table 2). As a result of the break-point effect of the Pro residue in the third position the second peptide nitrogen is effectively blocked, so preventing the formation of a normal 3N complex. However at around pH 9 a [CuH<sub>2</sub>L] species is formed. The

**Table 1.** Formation constants (log values) of  $H^+$  and  $Cu^{2+}$  complexes at 25 °C and  $I = 0.10 \text{ mol dm}^{-3}$  ( $KNO_3$ ), with standard deviations on the last figure given in parentheses

$H^+$ complexes:	$\beta_{HL}$	$\beta_{H_2L}$	$\beta_{H_3L}$	$\beta_{H_4L}$	$K(\text{TyrO}^-)$	$K(\text{NH}_2)$	$K(\text{CO}_2\text{H})$
Phe-Gly-Pro-Phe (HL)	7.53(1)	10.85(1)			—	7.53	3.32
Tyr-Gly-Pro-Phe ( $H_2L$ )	9.84(1)	17.36(1)	20.72(1)		9.84	7.52	3.36
Phe-Gly-Pro-Tyr ( $H_2L$ )	10.27(1)	17.85(1)	21.43(1)		10.27	7.58	3.58
Tyr-Gly-Pro-Tyr ( $H_3L$ ) <sup>a</sup>	10.16	19.96	27.50	30.52	10.16, 9.30	7.54	3.02
$Cu^{2+}$ complexes:	$\beta_{CuHL}$	$\beta_{CuL}$	$\beta_{CuH_2L}$	$\beta_{CuH_3L}$	$\beta_{(CuH_2L)_2}$	$\beta_{CuHL_2}$	
Phe-Gly-Pro-Phe	—	4.66(4)	0.03(1)	-8.93(2)			
Phe-Gly-Pro-Tyr	15.11(3)	10.39(1)	1.95(1)	-8.49(3)			
Gly-Gly-Pro-Gly <sup>b</sup>		4.95	-0.06	-9.46			
Tyr-Gly-Pro-Phe	14.60(6)	10.06(1)		-8.02(3)	6.88(4)	23.61(3)	

<sup>a</sup> Ref. 7. <sup>b</sup> Ref. 1.**Table 2.** Spectroscopic data for copper(II) complexes of Phe-Gly-Pro-Phe, Tyr-Gly-Pro-Phe, and Phe-Gly-Pro-Tyr

Ligand	Species	Visible <sup>a</sup> $\lambda/\text{nm}$	C.d. <sup>b</sup> $\lambda/\text{nm}$	E.s.r.	
				$g_{\parallel}$	$A_{\parallel}/G$
Phe-Gly-Pro-Phe	$[CuH_{-1}L]$	653 (99)	660 (-0.16) <sup>c</sup>	2.26	159
			315 (+0.08) <sup>d</sup>		
			300 (+0.06) <sup>e</sup>		
	$[CuH_{-2}L]$	650 (89)	273 (-0.36) <sup>f</sup>	2.26	136
			638 (+0.03) <sup>g</sup>		
			498 (-0.10) <sup>h</sup>		
Tyr-Gly-Pro-Phe	$[CuL]$	652 (80)	328 (-0.07) <sup>d</sup>	2.26	160
			275 (+0.35) <sup>f</sup>		
	$[(CuH_{-1}L)_2]$	680 (126) 387 (533)	665 (-0.12) <sup>c</sup>	2.25	142
			287 (-0.19) <sup>c</sup>		
			585 (-0.07) <sup>c</sup>		
			400 (-0.27) <sup>j</sup>		
Phe-Gly-Pro-Tyr	$[CuL]$	665 (86) 400 (10)	328 (-0.31) <sup>d</sup>	2.26	164
			288 (+0.31) <sup>i</sup>		
	$[CuH_{-1}L]$	650 (126) 407 (821)	275 (+0.22) <sup>i</sup>	2.26	137
			665 (-0.18) <sup>c</sup>		
			315 (+0.08) <sup>d</sup>		
			302 (+0.10) <sup>e</sup>		
			620 (+0.27) <sup>g</sup>		
			528 (-0.25) <sup>h</sup>		
			430 (+0.10) <sup>j</sup>		
			330 (-0.15) <sup>d</sup>		
			303 (+0.10) <sup>e</sup>		
			380 (-0.92) <sup>f</sup>		

<sup>a</sup> Approximate absorption coefficients in parentheses ( $\epsilon/\text{dm}^3 \text{ mol}^{-1} \text{ cm}^{-1}$ ). <sup>b</sup>  $\Delta\epsilon$  values in parentheses ( $\text{dm}^3 \text{ mol}^{-1} \text{ cm}^{-1}$ ). <sup>c</sup>  $B + E$   $d-d$  transition. <sup>d</sup>  $N^- \rightarrow Cu$  charge-transfer transition. <sup>e</sup>  $NH_2 \rightarrow Cu$  c.t. transition. <sup>f</sup> Intraring  $\pi-\pi^*$  transition. <sup>g</sup>  $B$   $d-d$  transition. <sup>h</sup>  $E$   $d-d$  transition. <sup>i</sup>  $NH_2 \rightarrow Cu$  c.t. transition + intraring  $\pi-\pi^*$  transition. <sup>j</sup>  $O^- \rightarrow Cu$  c.t. transition.

spectroscopic data confirm the formation of a new complex in this region (see Table 2) but the  $d-d$  transition energy continues to correspond well with that expected for a 2N complex.<sup>1-4,8,9</sup> The  $d-d$  transition band splits into two in the c.d. spectrum with bands at 638 ( $B$ ) and 498 nm ( $E$ ), probably as a result of a decrease in symmetry around the metal ion. This is also seen in the e.s.r. spectrum where there is a large decrease in the  $A_{\parallel}$  value compared to that found for the  $[CuH_{-1}L]$  complex (159 to 136 G), while the value for  $g_{\parallel}$  is unaltered (2.26). This effect suggests 2N bidentate co-ordination only ( $NH_2$  and  $N^-$ ), with another planar co-ordination site occupied by the  $OH^-$  ion.<sup>12,13</sup> The deprotonation reaction corresponding to  $[CuH_{-1}L] \rightarrow [CuH_{-2}L] + H^+$  must therefore correspond to the hydrolysis of a co-ordinated water molecule. The  $[CuH_{-1}L]$  complex would involve weak co-ordination to the carbonyl oxygen of the Gly residue and it is probably this bond which is broken, and replaced with  $OH^-$  co-ordination, in the above reaction. This would explain why the deprotonation constant ( $\log K = -8.96$ ) is numerically a little lower than might be expected.

There was no evidence for the formation of a 3N complex although such a species could be visualised through the formation of a large chelate ring spanning the Pro residue.

Solutions of both Tyr-Gly-Pro-Phe and Phe-Gly-Pro-Tyr became lime-green in the presence of  $Cu^{II}$  as the pH was raised above 8. This was a result of bonding between  $Cu^{II}$  and the phenolate O of the Tyr residues as is shown by a charge-transfer transition in both the visible and c.d. spectra at around 400 nm.<sup>7,14</sup> Hence above pH 8 both ligands form complexes with  $Cu^{II}$  which involve  $TyrO^-$  bonding to the metal ion. While Phe-Gly-Pro-Tyr can form monomeric planar complexes involving both the amino N and  $TyrO^-$  donor centres, it is sterically impossible for Tyr-Gly-Pro-Phe to form such a complex, hence complex formation between Tyr-Gly-Pro-Phe and  $Cu^{II}$  must involve binuclear species. Potentiometric data for both tetrapeptides were treated assuming mononuclear complex formation only and a mixture of mono- and bi-nuclear co-ordination. It was found that, for Phe-Gly-Pro-Tyr, the statistical fit for mononuclear complex formation only was markedly better than

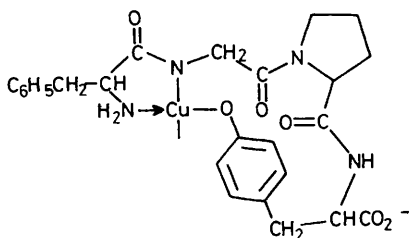

Figure 2. Proposed structure for the  $[\text{CuH}_1\text{L}]$  complex of Phe-Gly-Pro-Tyr

for the models including binuclear co-ordination. Hence it was concluded that the data for this peptide should be satisfied by including only the mononuclear complexes given in Table 1. With Tyr-Gly-Pro-Phe both binuclear and mononuclear species could be accommodated but, in this case, there was no longer any statistical advantage in favour of the mononuclear species only. In fact the model including the binuclear species  $[(\text{CuH}_1\text{L})_2]$  was entirely self-consistent over a number of different titrations. Since the spectroscopic evidence also required binuclear complexation, with  $\text{TyrO}^- - \text{Cu}$  as well as  $\text{NH}_2 - \text{Cu}$  and  $\text{N}^- - \text{Cu}$  bonding, this model was selected and the stability constants are given in Table 1. The c.d. spectra for the  $d-d$  transition region above pH 8 also differ between the two ligands, supporting the above models. With Phe-Gly-Pro-Tyr there were two components, *B* and *E*, while for Tyr-Gly-Pro-Phe, where dimer formation is proposed, only one (*B* + *E*) band was observed. In addition, the  $A_{\parallel}$  value for the monomeric species (137 G) is lower than for the dimer (142 G).<sup>12,13</sup> Both these facts indicate that the symmetry around the metal ion is lower with Phe-Gly-Pro-Tyr (monomer) than with Tyr-Gly-Pro-Phe (dimer). Species-distribution curves calculated for the models given in Table 1 are shown in Figure 1(b) and (c).

With both ligands the first complex to form is the  $[\text{CuHL}]$  species. These would be comparable to the  $[\text{CuL}]$  species with Phe-Gly-Pro-Phe, after allowing for the Tyr protonation constants, *i.e.* 1N complexes. The measured stability constants are in good agreement with this (see Table 1). The next complex,  $[\text{CuL}]$ , would, for the same reasons, correspond to the  $[\text{CuH}_1\text{L}]$  complex (2N co-ordination) of Phe-Gly-Pro-Phe. This again is supported by both the potentiometric (see Table 1) and spectroscopic results (see Table 2). Since the Pro residue in the third position of the tetrapeptide chain prevents further sequential peptide N co-ordination, the next proton displacement is from the phenolic OH of the Tyr residue with simultaneous co-ordination to  $\text{Cu}^{\text{II}}$ , hence the appearance of a yellow band at around 400 nm.

From the evidence, this monomeric complex with Phe-Gly-Pro-Tyr is  $[\text{CuH}_1\text{L}]$  with 2N co-ordination and the formation of a large chelate ring to the  $\text{TyrO}^-$  donor atom as shown in Figure 2. Scale models show this to be a particularly favourable conformation and, if this is the bonding mode, the stability of the  $[\text{CuH}_1\text{L}]$  complex with Phe-Gly-Pro-Tyr (log value 1.95) should be greater than that of the corresponding complex with Phe-Gly-Pro-Phe (0.03). This enhancement in stability of nearly two orders of magnitude must be the result of  $\text{TyrO}^- - \text{Cu}$  co-ordination. The other planar co-ordination site would be taken up by either the carbonyl oxygen of the Gly residue or a water molecule. Above pH 10 a further deprotonation gives the  $[\text{CuH}_2\text{L}]$  complex. The deprotonation constant ( $-10.44$ ) is entirely consistent with hydrolysis of a co-ordinated water molecule. This deprotonation appears to be accompanied by breaking of the  $\text{TyrO}^- - \text{Cu}$  bond since the absorption coefficient of the charge-transfer transition drops from  $830 \text{ dm}^3 \text{ mol}^{-1} \text{ cm}^{-1}$  at pH 10 to  $590 \text{ dm}^3 \text{ mol}^{-1} \text{ cm}^{-1}$  at pH 11.5.

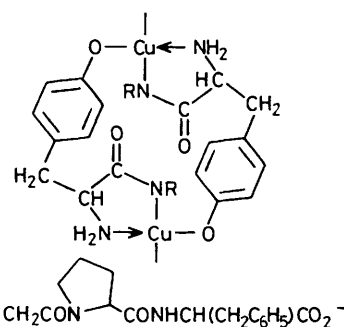

Figure 3. Proposed structure for the  $[(\text{CuH}_1\text{L})_2]$  complex of Tyr-Gly-Pro-Phe

With Tyr-Gly-Pro-Phe the  $[(\text{CuH}_1\text{L})_2]$  dimer would be expected to have a structure similar to that shown in Figure 3, which has the required co-ordination centres and, from molecular models, would be a stable dimer. Above pH 9.5 further deprotonation occurs to give the species  $[\text{CuH}_2\text{L}]$ . This species presumably results from the hydrolysis of a co-ordinated water molecule, accompanied by the breaking of the  $\text{TyrO}^- - \text{Cu}$  bond which stabilised the dimer. As with Phe-Gly-Pro-Tyr, there is a decrease in the intensity of the  $\text{TyrO}^- - \text{Cu}$  charge-transfer transition as the pH is raised above 10 (*e.g.*  $550 \text{ dm}^3 \text{ mol}^{-1} \text{ cm}^{-1}$  at pH 10 to  $270 \text{ dm}^3 \text{ mol}^{-1} \text{ cm}^{-1}$  at pH 11.2) so supporting this breaking of the  $\text{O}^- - \text{Cu}$  bond following hydrolysis. Titrations with an excess of ligand suggested the presence of a bis complex,  $[\text{CuHL}_2]$  between pH 7 and 8, hence the constant is included in Table 1. However this species made an insignificant contribution towards the species-distribution curves of 1:1  $\text{Cu}^{2+} - \text{Tyr-Gly-Pro-Phe}$  mixtures shown in Figure 1(c).

#### Acknowledgements

Two of us (W. B. and H. K.) thank the Polish Academy of Sciences for their financial support (Project 01.12).

#### References

- 1 M. Bataille, G. Formicka-Kozłowska, H. Kozłowski, L. D. Pettit, and I. Steel, *J. Chem. Soc., Chem. Commun.*, 1984, 231.
- 2 L. D. Pettit, I. Steel, G. Formicka-Kozłowska, T. Tatarowski, and M. Bataille, *J. Chem. Soc., Dalton Trans.*, 1985, 535.
- 3 H. Kozłowski, M. Bezer, L. D. Pettit, M. Bataille, and B. Hecquet, *J. Inorg. Biochem.*, 1983, **18**, 231.
- 4 G. Formicka-Kozłowska, D. Konopinska, H. Kozłowski, and B. Decock-Le Reverend, *Inorg. Chim. Acta*, 1983, **78**, L47.
- 5 H. Kozłowski, G. Formicka-Kozłowska, L. D. Pettit, and I. Steel, 'Frontiers in Bioinorganic Chemistry,' ed. A. V. Xavier, VCH, Weinheim, 1986, p. 668.
- 6 M. Bataille, L. D. Pettit, I. Steel, H. Kozłowski, and T. Tatarowski, *J. Inorg. Biochem.*, 1985, **24**, 211.
- 7 L. D. Pettit, I. Steel, T. Kowalik, H. Kozłowski, and M. Bataille, *J. Chem. Soc., Dalton Trans.*, 1985, 1201.
- 8 H. Sigel and R. B. Martin, *Chem. Rev.*, 1982, **82**, 353.
- 9 B. Decock-Le Reverend, L. Andrianarijaona, C. Livera, L. D. Pettit, I. Steel, and H. Kozłowski, *J. Chem. Soc., Dalton Trans.*, 1986, 2221.
- 10 H. M. Irving, M. G. Miles, and L. D. Pettit, *Anal. Chim. Acta*, 1967, **38**, 475.
- 11 P. Gans, A. Sabatini, and A. Vacca, *J. Chem. Soc., Dalton Trans.*, 1985, 1196.
- 12 H. Kozłowski, *Chem. Phys. Lett.*, 1977, **46**, 519.
- 13 H. Kozłowski and J. Baranowski, *Inorg. Nucl. Chem. Lett.*, 1978, **14**, 315.
- 14 R. J. W. Hefford and L. D. Pettit, *J. Chem. Soc., Dalton Trans.*, 1981, 1331.